

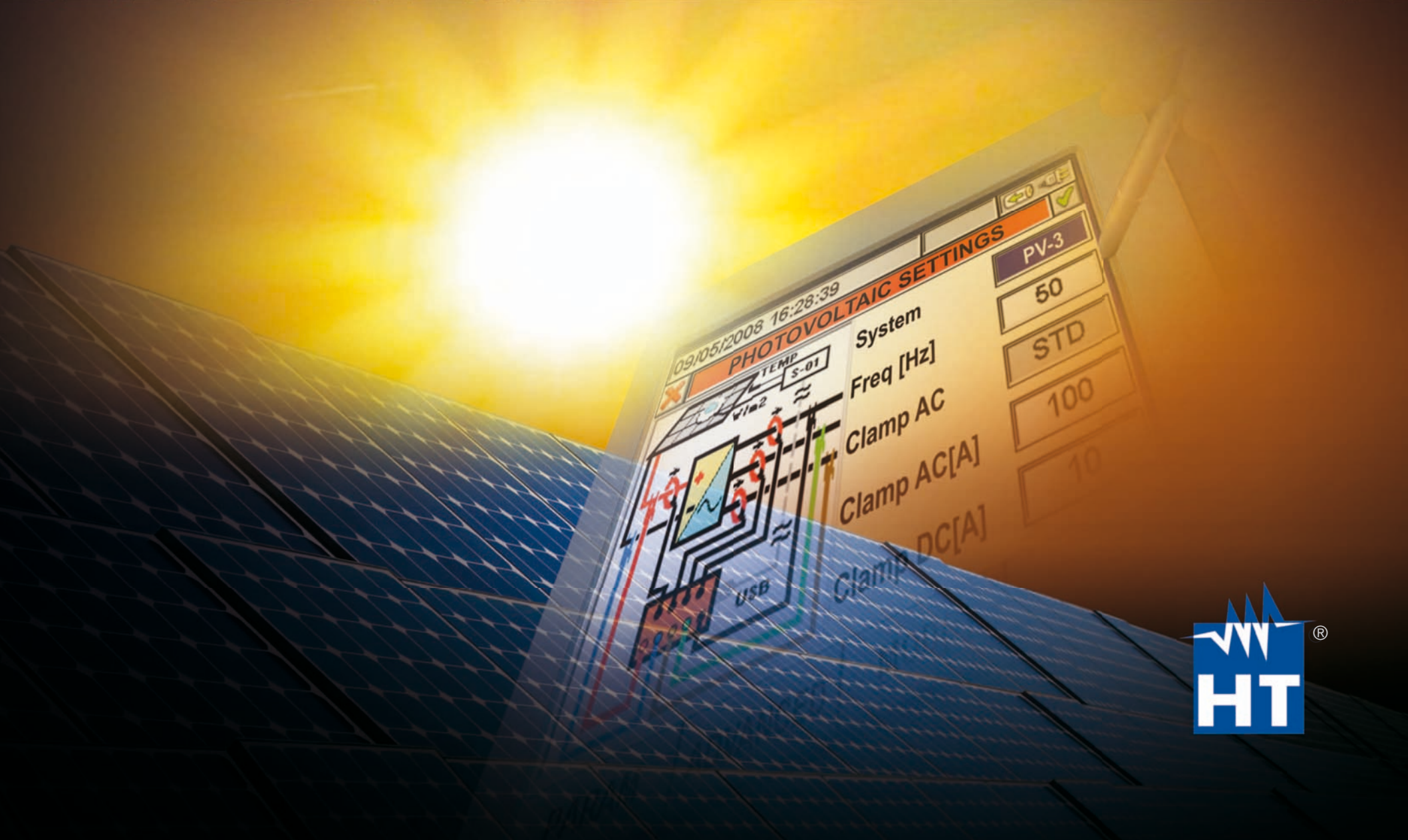

INSTRUMENTS FOR VERIFICATION ANALYSIS AND TESTING OF PHOTOVOLTAIC SYSTEMS
SOLAR 200 • SOLAR 300N • I-V400 • SOLARI-V • MPP 300 • THT 41



SOLAR 300N

3 PHASE PV SYSTEM ANALYZER

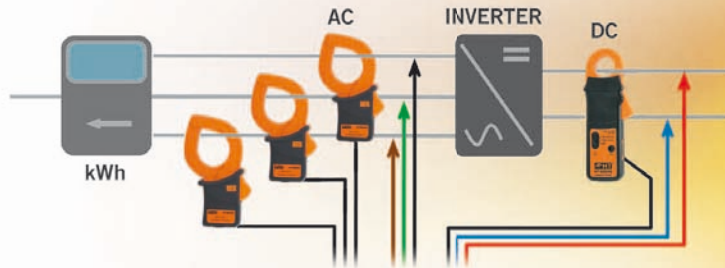

SOLAR-02
Synchronizing
Measuring
Downloading

°C W/m²

I-V 400

I-V CURVE TRACER

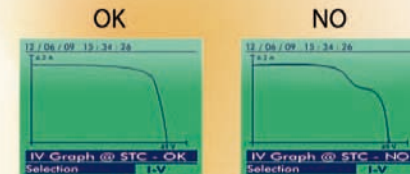

| INSTRUMENTS FOR TESTING AND VERIFYING PHOTOVOLTAIC INSTALLATIONS | NEW | | NEW | | |
|---|-------------|-----------------|-----------------------------|----------------|--------------------------------|
| | MPP 300 | SOLAR 200 | SOLAR 300N | I-V 400 | SOLAR I-V |
| Continuity of protective conductors with 200mA | | • | | | |
| Insulation with test voltages of 50, 100, 250, 500, 1000V DC | | • | | | |
| Tripping time and current of RCDs type A, AC up to 500mA | | • | | | |
| Impedance Line/Loop, also with high resolution (0.1mΩ), and Ipsc calculation | | • | | | |
| Total earth resistance with no RCD tripping | | • | | | |
| Phase sequence | | • | • | | |
| DC/AC TRMS voltage/current on single-phase systems | • | | • | | • |
| DC/AC TRMS voltage/current on three-phase systems | • | | • | | |
| DC/AC powers on single-phase systems | • | | • | | • |
| DC/AC powers on three-phase systems | • | | • | | |
| Power factor (cos φ) on single-/three-phase systems | | | • | | |
| Energies on single-phase and three-phase systems | | | • | | |
| Recording of mains parameters with programmable IP | | | • (1s-60m) | | • (5s-60m) |
| Maximum number of quantities contemporarily selectable | | | 251 | | 9 |
| Harmonic analysis of voltages/currents up to the 49th order | | | • | | |
| Detection of voltage anomalies (dips, peaks) in 10ms | | | • | | |
| Complete analysis according to EN50160 | | | • | | |
| Inrush current of electric motors | | | • | | |
| Voltage fast transients (spikes) with a resolution of 5μs (200kHz) | | | • | | |
| Voltage unbalance (NEG%, ZERO%) and Flicker (Pst, Plt) | | | • | | |
| Display of vector diagrams and waveforms of voltages/currents | | | • | | |
| Indication of recording autonomy | | | • | | |
| Default and customizable recordings | | | • | | |
| TFT touch-screen colour display | | | • | | |
| LCD custom backlit display | | • | | • | • |
| Power supply by rechargeable battery and by means of external power supplier | • | | • | | |
| Use of remote unit | • | | • | • | • |
| Efficiency measurement/recording of single-string system | • | | • | | • |
| Efficiency measurement/recording of multi-string system up to 3 MPPTs | • | | • (with MPP 300) | | • (with MPP 300) |
| Efficiency measurement/recording of single-phase system | • | | • | | • |
| Efficiency measurement/recording of three-phase system | • | | • | | • (with MPPT 300) |
| Irradiation measurement with reference solar cell | | | • | • | • |
| Temperature measurement of modules and environment | | | • | • | • |
| Detection of I-V curve of modules and strings | | | | • (1000V, 10A) | • (1000V, 10A) |
| Internal database of PV modules | | | | • | • |
| Measurement of modules and strings data (Voc, Vmpp, Impp, Isc, Pmax, FF, Dpmax) | | | | • | • |
| Auto power off | • | • | • | • | • |
| Memory capacity | 2 Mbyte | 500 locations | 1 month @ Pl=15min, 251 par | > 200 curves | > 200 curves 8 days @ Pl=10min |
| Extension of internal memory with external Compact Flash | | | • | | |
| USB port for connection of external memory sticks | | | • | | |
| PC interface with software for Windows | | • (optical/USB) | • (USB) | • (optica/USB) | • (optica/USB) |
| Context-sensitive help on the display | | • | • | • | • |
| Saving of recordings and instant values | | | • | • | • |
| Dimensions (LxWxH) (mm) | 300x265x140 | 235x165x75 | 235x165x75 | 235x165x75 | 235x165x75 |
| Weight (batteries included) (Kg) | 2,3 Kg | 1,2 Kg | 1 Kg | 1,2 Kg | 1,3 Kg |
| Safety in compliance with IEC/EN61010-1 | • | • | • | • | • |

SOLAR 300N

MULTIFUNCTION INSTRUMENT FOR TESTING SINGLE-PHASE AND THREE-PHASE PHOTOVOLTAIC SYSTEMS AND ANALYZING MAINS QUALITY IN COMPLIANCE WITH STANDARD EN50160

SOLAR 300N allows carrying out all tests required for the verification of the efficiency of single-phase and three-phase photovoltaic systems. Testing photovoltaic systems requires contemporarily measuring environmental parameters (incident irradiation of modules, temperature of environment and modules) and electric parameters (continuous power, alternating power, etc.). Typically, modules and inverter can be positioned even at several tens of meters of distance, thus forcing the operator to carry out measurements in different places far from each other at the same time. To carry out these operations, connections by means of long cables or (wireless) radio connections could be necessary, but both these solutions are not acceptable. Cables could hamper the operator's movements or be a hindrance, while radio waves would be attenuated by floors, reinforced concrete or metal structures, thus making communication impossible. In order to avoid the above-mentioned problems and to carry out measurements with the necessary contemporaneity, SOLAR 300N is provided with a remote unit, synchronized with the main unit. The remote unit is positioned next to the photovoltaic modules and it is connected to the probes for measuring environmental parameters (irradiation and temperature). SOLAR 300N is connected upstream and downstream of the inverter in order to acquire the electric parameters (continuous power and alternating power). The synchronization between the two units guarantees the necessary contemporaneity of measurements, the two separate and independent units make measurements comfortable and safe.

The instrument can be interfaced with accessory MPP300, which extends the characteristics of SOLAR 300N by enabling recordings on single-phase and three-phase, single-string and multi-string (up to three strings), single-inverter and multi-inverter photovoltaic systems (therefore also in three-phase systems provided with three single-phase inverters).

SOLAR 300N is also a powerful instrument for the complete analysis of mains quality in compliance with standard EN50160 (harmonic analysis, analysis of voltage anomalies, Flicker, unbalance, etc.). The management software TopView also provides the possibility of creating professional reports, which can be customized by adding the company's logo, the customer's data, comments, etc.

(multi-string with MPP 300 - see pag. 10)

FUNCTIONS

- DC/AC TRMS (single/three-phase) voltage measurement
- DC/AC TRMS (single/three-phase) current measurement
- DC/AC (single/three-phase) power measurement
- AC (single/three-phase) energy measurement
- Measurement of power factor (single/three-phase)
- Measurement of solar irradiation [W/m²]
- Measurement of environmental and module temperature
- Three-phase up to three strings PV systems (with MPP300)
- Recording of voltage and current harmonics up to the 49th
- Recording of voltage anomalies (dips, peaks)
- Flicker analysis in compliance with standard EN50160
- Recording of starting currents with a resolution of 10ms
- Recording of fast voltage (spikes) with a resolution of 5µs
- Analysis of mains quality in compliance with EN50160
- Numerical and graphical display of each quantity
- Recalling results on the display
- TFT colour display with touch screen
- Power supply with rechargeable Li-ION battery
- Memory extension by means of CF card
- Data transfer to external USB memory (memory stick)
- USB port for PC connection
- Help on line on the display

GENERAL CHARACTERISTICS

| | |
|-------------------------|--|
| Display: | TFT, 65536 colours, (320x240pxl), high contrast, touch screen |
| Power supply: | 1x3.7V rechargeable Li-ION battery with external power supply, duration > 6h, auto power off after 5 min in stand-by |
| Internal memory: | 15Mbyte (duration approximately 3 months @ IP = 15min and 251 parameters selected) |
| Memory extension: | compact flash (CF card) |
| PC interface: | USB 2.0 |
| Safety: | IEC/EN61010-1 |
| Insulation: | double insulation |
| Pollution degree: | 2 |
| Measurement category: | CAT IV 600V (to earth) CAT III 1000V (between inputs) |
| Unbalance: | IEC/EN61000-4-7 |
| Power quality: | IEC/EN50160 |
| Flicker: | IEC/EN61000-4-15 |
| Electric power quality: | IEC/EN61000-4-30 Classe B |
| Dimensions: | 235x165x75mm |
| Weight (with battery): | approx. 1kg |



WITH
TOUCH
SCREEN

Some standard
accessories



HT4004N

SOLAR 300N
HV00300N

| ACCESSORIES SUPPLIED | Code |
|--|-------------|
| Series accessories | |
| Remote unit to record irradiation and temperature | SOLAR-02 |
| Kit of 5 cables + alligator clips for voltage measurement | KIT800 |
| Transducer for AC 0÷200A, diameter 40mm, 3 pcs | HT4005K |
| Transducer for AC/DC currents 0÷10 - 0÷100A, diameter 32mm | HT4004N |
| Sensor for irradiation measurement | HT304 |
| Probe PT1000 for panel temperature | PT300N |
| AC/DC power supply | A0055 |
| Rechargeable 3.7V Li-ION battery | |
| Touch-screen pen | PT400 |
| Widows software + USB cable | TOPVIEW2007 |
| Rigid transport suitcase | VA400 |
| User manual on CD-ROM | |
| Rapid user guide | |
| Calibration certificate ISO9000 | |
| Opzional accessories | |
| Multi-string three-phase adaptor | MPP300 |
| Unbatteried transducer for AC/DC currents 0÷10A, 0÷100A, max. diameter 32mm* | HT4004P |
| Transducer for AC currents 0÷5 - 0÷100 A, diameter 20mm | HT4005N |
| Rigid clamp AC 1-100-1000A/1V, diameter 54mm | HT96U |
| Rigid clamp AC 10-100-1000A/1V, diameter 54mm | HT97U |
| Rigid clamp DC 1000A/1V, diameter 50mm | HT98U |
| Rigid clamp AC 200-2000A/1V, diameter 70mm | HP30C2 |
| Rigid clamp AC 3000A/1V, diameter 70mm | HP30C3 |
| Flexible clamp AC 3000A, diameter 174mm (**) | HTFLEX33D |
| Flexible clamp AC 3000A, diameter 274mm (**) | HTFLEX35 |
| Interface 3x1-5A/1V for connection of external CTs | HT903 |
| Kit of belts for slinging the instrument over one's shoulder | SP-0400 |
| Connector with magnetic tip | 606-IECN |

(*) to be used with MPP300 only (**) only for using the instrument as mains analyzer

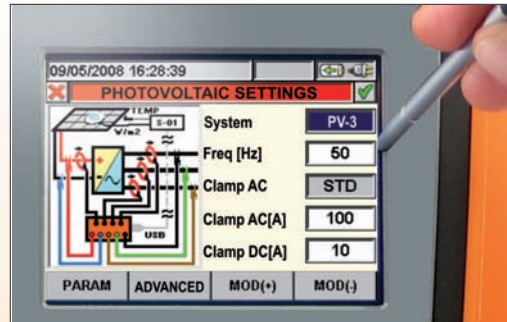

Graphical touch-screen display

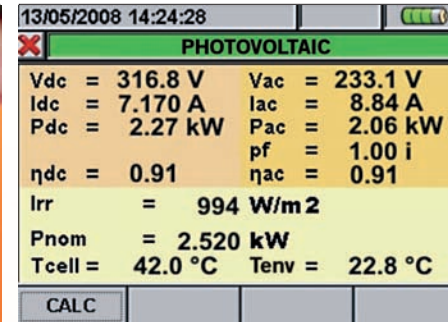

Testing result on the display of SOLAR 300N

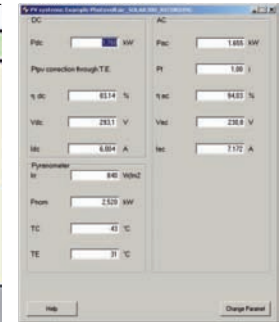

Testing result on TopView software

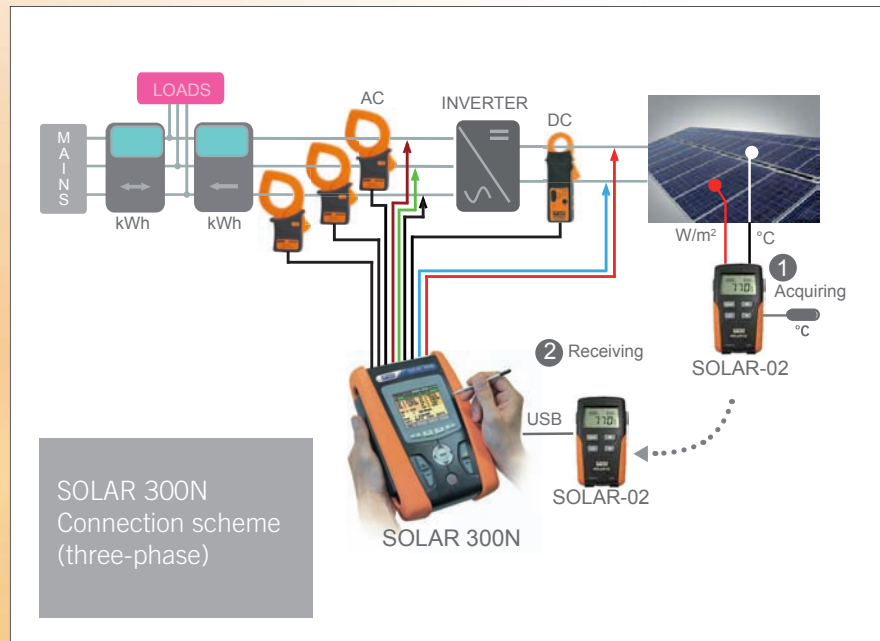

SOLAR 300N
Connection scheme
(three-phase)



Professional transport suitcase



HT4005K (3 pcs)



SOLAR-02



HT304

MULTIFUNCTION INSTRUMENT FOR VERIFICATION OF I-V CHARACTERISTIC OF PHOTOVOLTAIC STRINGS AND MODULES

I-V 400 is the ideal solution for the ordinary and scheduled maintenance of photovoltaic systems. With I-V 400, searching for possible failures and problems in systems is extremely rapid, efficient and intuitive. I-V 400 carries out the field measurement of the I-V characteristic and of the main characteristic parameters both of a single module and of module strings. The instrument measures, together with the I-V characteristic of the device being tested, also the values of its temperature and incident irradiation. The acquired data are then processed to extrapolate the I-V characteristic at standard test conditions (STC) in order to proceed with the comparison with the nominal data declared by the modules' manufacturer, thus immediately determining whether or not the string or the module being tested respects the characteristics declared by the manufacturer.

In some PV installations, such as roof-top installations, it may be difficult to access the module output cables. An access to the cables at the combiner box or at the inverter's inputs may be the only chance. In this case the measurement of I-V characteristics can be achieved by measuring the environmental parameters (irradiation and temperature) through the remote optional unit SOLAR-02. The remote unit is positioned next to the photovoltaic modules and it is connected to the probes for measuring environmental parameters. The synchronization between the two units guarantees the necessary contemporaneity of measurements making possible the extrapolation of the I-V curve at STC without using long extension cords cable.

Output current or voltage from the module or string is measured with the 4-terminal method, which allows extending the measurement cables without requiring any compensation for their resistance, thus always providing accurate and precise measurements. In its internal memory, I-V 400 manages a database of photovoltaic modules, which can be updated at any time both via the management software and directly on the instrument. Together with the measurement of the I-V characteristic and the extrapolation of the characteristic at standard test conditions, I-V 400 compares the obtained values with the values declared by the manufacturer, immediately providing the OK / NO result of the test. The operator must not do any calculation, nor any difficult operation. The instrument carries out the comparison rapidly and automatically.

FUNCTIONS

- Meas. of output voltage from module/string up to 1000V DC
- Meas. of output current from module/string up to 10A DC
- Measurement of solar irradiation [W/m²] with reference cell
- Measurement of module temperature, automatic or by means of external probe
- Meas. of output DC and nominal power of module/string
- Synchronization with remote unit SOLAR-02
- Numerical and graphical display of I-V characteristic
- Measurement of the resistance of photovoltaic module series
- Mechanical inclinometer for the detection of the incidence angle of solar irradiation
- 4-terminal measuring method
- Extrapolation to standard test conditions (STC)
- Evaluation of testing result: OK / NO
- Management of up to 30 types of photovoltaic modules in the internal database
- Internal memory for data saving
- Recalling results on the display
- Optical/USB port for PC connection
- Help on line on the display

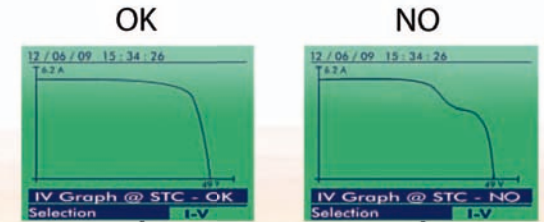

Some standard accessories



HT304

M304



I-V 400
HV00400V

GENERAL CHARACTERISTICS

| | |
|------------------------------|---|
| Display: | LCD Custom, 128x128pxl, backlit |
| Power supply: | 6x1.5V alkaline bat. type AA LR06 |
| Auto power off: | after 5 minutes in stand-by |
| Internal memory: | 256kBytes |
| Curves which can saved: | > 200 |
| PC interface: | optoisolated optical/USB port |
| Safety: | IEC/EN61010-1 |
| Measuring accessory safety: | IEC/EN61010-031, IEC/EN10-032 |
| Measures: | IEC/EN 60891 |
| Insulation: | double insulation |
| Pollution degree: | 2 |
| Measurement category: | CAT II 1000V, CAT III 300V (to earth) Max 1000V between inputs |
| Dimensions: | 235x165x75mm |
| Weight (batteries included): | 1.2kg |

ACCESSORIES SUPPLIED

| | Code |
|--|-------------|
| Series accessories | |
| Kit of 4 cables with 4mm banana plugs + 4 alligator clips | KITGSC4 |
| Kit of 2 adapters with MC3 compatible connectors | KITPVMC3 |
| Kit of 2 adapters with MC4 compatible connectors | KITPVMC4 |
| Reference cell for irradiation measurement | HT304 |
| Mechanical inclinometer | M304 |
| Windows software + optical/USB cable C2006 | TOPVIEW2006 |
| Transport bag | BORSA2051 |
| User manual | |
| Calibration certificate ISO9000 | |
| Optional accessories | |
| Probe PT1000 for cell temperature measurement | PT300N |
| Kit of belts for slinging the instrument over one's shoulder | SP-0400 |
| Remote unit to record irradiation and temperature | SOLAR-02 |
| Kit of 2 cables banana 4mm, green/black, 25m | KITPVEXT25M |
| Rigid transport suitcase | VA400 |

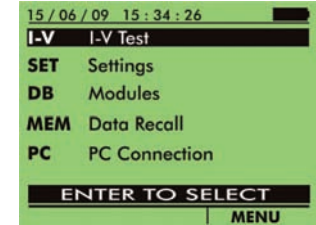
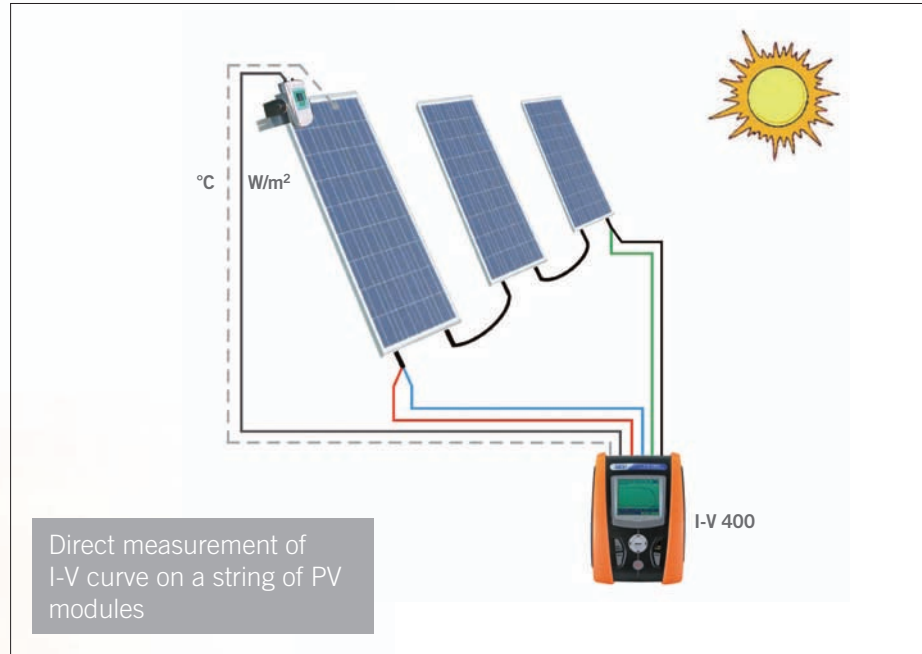

Simple and intuitive user interface



Numerical display of results with OK result

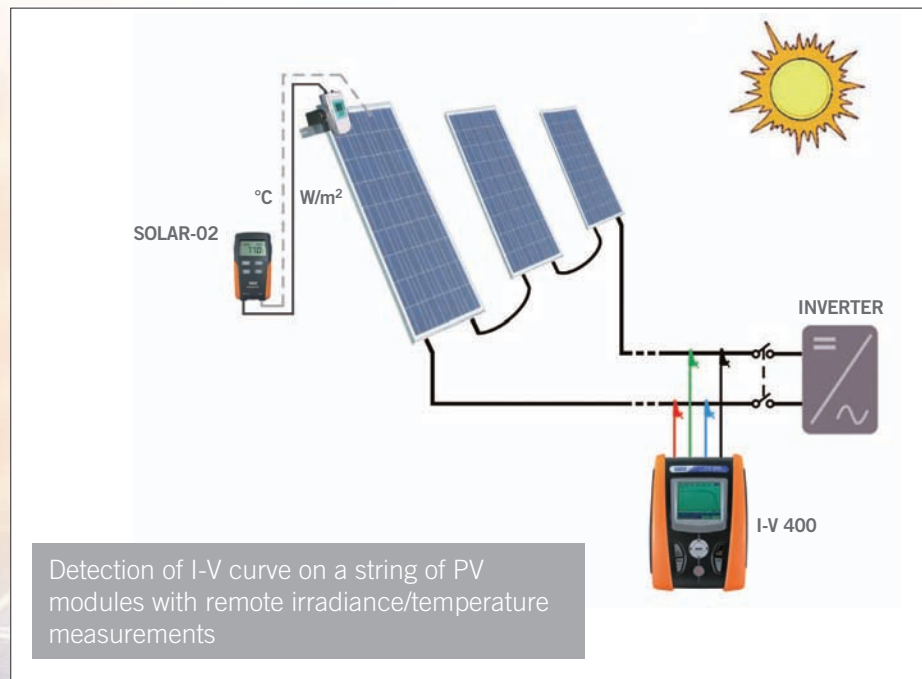

Creation of a customizable database of photovoltaic modules

SOLAR I-V

MULTIFUNCTION INSTRUMENT FOR TESTING AND VERIFYING SINGLE-PHASE PHOTOVOLTAIC INSTALLATIONS

SOLAR I-V has been designed to meet any requirement of photovoltaic installation specialists. Further to providing the possibility of measuring and recording the efficiency of single-string and single-phase photovoltaic systems, SOLAR I-V also measures the I-V characteristic both of a single module and of module strings. Thanks to SOLAR I-V, the operator can test the photovoltaic system and, should it give a negative result, immediately identify the problems of the system in order to promptly solve them. SOLAR I-V is provided with the remote unit SOLAR-02 which permits the remote measuring of irradiation and temperature with preliminary automatic synchronization between main unit and remote unit. SOLAR-02 is positioned next to the photovoltaic modules and it is connected to the probes for measuring environmental parameters. The synchronization between the two units guarantees the necessary contemporaneity of measurements. In the case of PV efficiency recordings, this grants the right efficiency calculation. For I-V curve measurements, the synchronization permits to extrapolate the I-V curve at STC without using long extension cords cable. SOLAR I-V allows carrying out efficiency recordings over time with programmable integration period from 5 seconds to 60 minutes. Each value is automatically saved in the internal memory and can be downloaded onto the PC for subsequent analyses. The measured I-V characteristic is not affected by the resistance of the measurement cables, as the measurement is carried out with the 4-terminal measuring method. SOLAR I-V also manages a database of photovoltaic modules, which can be updated at any time. The measured values, correctly reported at standard test conditions, are immediately compared with the values declared by the manufacturer to give the OK / NO result of the test. The operator must not do any calculation, the instrument carries out the comparison rapidly and automatically.

The instrument can be interfaced with accessory MPP300, which extends the characteristics of SOLAR I-V by enabling recordings on single-phase and three-phase, single-string and multi-string (up to three strings), single-inverter and multi-inverter photovoltaic systems (therefore also in three-phase systems provided with three single-phase inverters).

(multi-string with MPP 300 - see pag. 10)

FUNCTIONS

Photovoltaic installation testing

- Measurement of DC/AC TRMS voltage and current
 - Measurement of DC/AC powers on single-phase systems
 - Measurement of solar irradiation [W/m²] with reference cell
 - Measurement of environmental and module temperature by means of external probe
 - Synchronization with remote unit SOLAR-02
 - Display of real-time irradiation and temperature
 - Use of PDC compensation ratios according to environmental and module temperature
 - Three-phase up to three strings PV systems (with MPP300)
 - Recording of parameters with programmable IP (5s – 60min)
- ### I-V characteristic measurement
- Meas. of output voltage from module/string up to 1000V DC
 - Meas. of output current from module/string up to 10A DC
 - Measurement of solar irradiation [W/m²] with reference cell
 - Measurement of module temperature, automatic or by means of external probe
 - Meas. of output DC and nominal power from module/string
 - Synchronization with remote unit SOLAR-02
 - Numerical and graphical display of I-V characteristic
 - Measurement of the resistance of photovoltaic module series
 - Mechanical inclinometer for the detection of the incidence angle of solar irradiation
 - 4-terminal measuring method
 - Extrapolation to standard test conditions (STC)
 - Evaluation of testing result: OK / NO
 - Management of up to 30 types of photovoltaic modules in the internal database

Common characteristics

- Internal memory for data saving
- Recalling results on the display
- Optical/USB port for PC connection
- Help on line on the display

Some standard accessories



HT4004N

HT4005K

SOLAR-02

HT304

M304

GENERAL CHARACTERISTICS

| | |
|------------------------------|---|
| Display: | LCD custom, 128x128pxl, backlit |
| Power supply: | 6x1.5V alkaline bat. type AA LR06 |
| Auto power off: | after 5 minutes in stand-by |
| PV testing duration: | 1.5 hours (@IP=5s); 8 days (@IP=10min) |
| Curves which can be saved: | > 200 curves |
| PC interface: | optoisolated optical/USB port |
| Safety: | IEC/EN61010-1 |
| Measuring accessory safety: | IEC/EN61010-031, IEC/EN61010-032 |
| Measures on PV modules: | IEC/EN60891 |
| Insulation | double insulation |
| Pollution degree: | 2 |
| Measurement category: | CAT II 1000V DC, CAT III 300V (to earth) Max 1000V between inputs |
| Dimensions: | 235x165x75mm |
| Weight (batteries included): | 1.3kg |



SOLAR I-V
HV00001V

| ACCESSORIES SUPPLIED | Code |
|---|-------------|
| Series accessories | |
| Remote unit to record irradiation and temperature | SOLAR-02 |
| Kit of 4 cables with 4mm banana plugs + 4 alligator clips | KITGSC4 |
| Kit of 2 adapters with MC3 compatible connectors | KITPVMC3 |
| Kit of 2 adapters with MC4 compatible connectors | KITPVMC4 |
| Transducer for AC 0÷200A, diameter 40mm | HT4005K |
| Transducer for AC/DC currents 0÷10 - 0÷100A, diameter 32mm | HT4004N |
| Reference cell for irradiation measurement | HT304 |
| Probe PT1000 for environmental and module temperature | PT300N |
| Mechanical inclinometer | M304 |
| Windows software + optical/USB cable C2006 | TOPVIEW2006 |
| Transport bag | BORSA2051 |
| User manual on CD-ROM | |
| Calibration certificate ISO9000 | |
| Rapid user guide | |
| Opzional accessories | |
| Multi-string three-phase adaptor | MPP300 |
| Unbattered transducer for AC/DC currents 0÷10A, 0÷100A, max. diameter 32mm* | HT4004P |
| Transducer for AC currents 0÷5 - 0÷100 A, diameter 20mm | HT4005N |
| Rigid clamp AC 1-100-1000A/1V, diameter 54mm | HT96U |
| Rigid clamp AC 10-100-1000A/1V, diameter 54mm | HT97U |
| Rigid clamp DC 1000A/1V, diameter 50mm | HT98U |
| Kit of belts for slinging the instrument over one's shoulder | SP-0400 |
| Kit of 2 cables banana 4mm, green/black, 25m | KITPVEXT25M |
| Rigid transport suitcase | VA400 |
| Connector with magnetic tip | 606-IECN |

(*) to be used with MPP 300 only

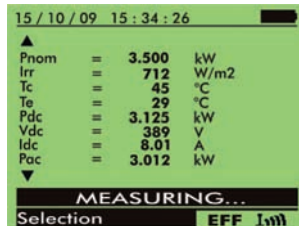

Testing / Recording in progress

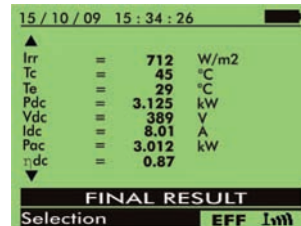

Testing result of photovoltaic system



Numerical display of results with OK result

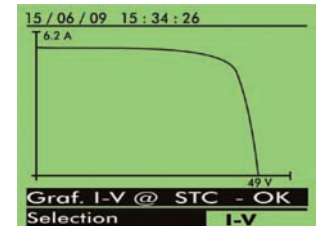

Graphical display of an I-V curve with OK result

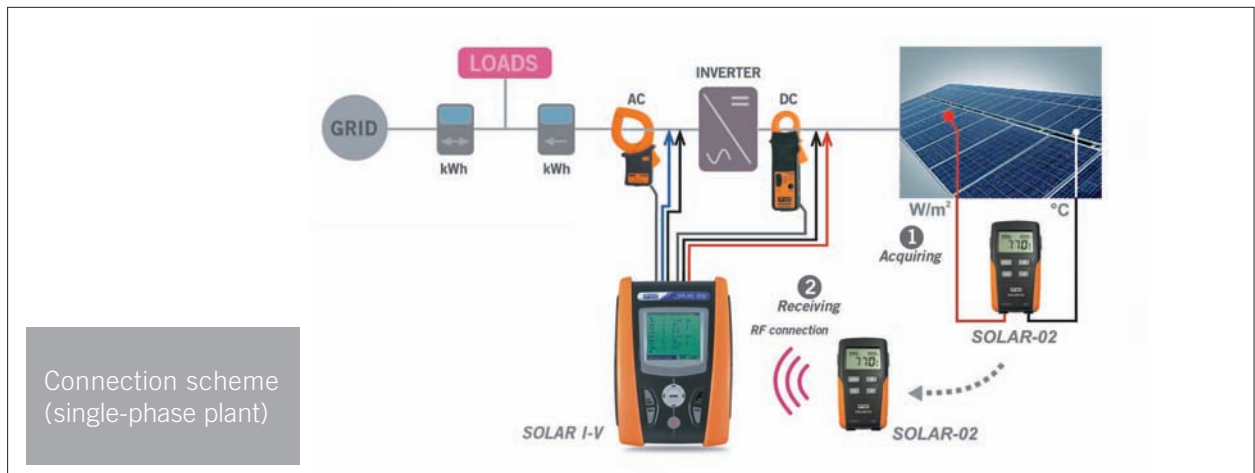
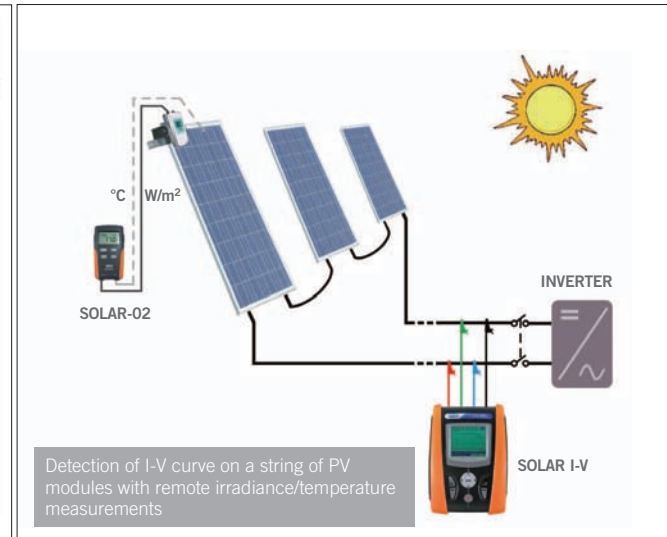
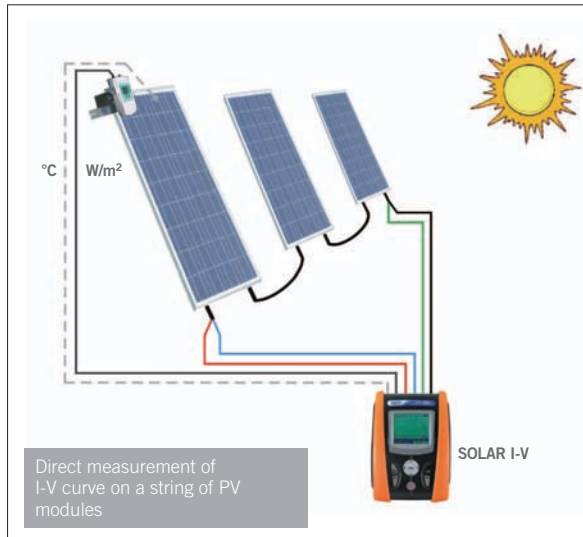

MPP 300

ACCESSORY FOR MEASURING AND RECORDING THE EFFICIENCY OF SINGLE-PHASE AND THREE-PHASE MULTI-STRING SYSTEMS

The innovative accessory MPP300, used together with SOLAR300N or SOLAR I-V, allows measuring and recording the main parameters which characterize single-phase and three-phase, single-string and multi-string (up to three strings) photovoltaic systems. MPP300 is perfect for use in systems with three-MPPT three-phase inverter and in three-phase systems provided with three single-phase inverters. MPP300 is provided with a practical anti-shock “field” case, lightweight and small in size. The front panel carries the LEDs for operating information and the DC and AC inputs for upstream and downstream connection of the inverter(s). MPP300 interfaces with SOLAR300N via USB connection and SOLAR I-V via wireless connection. SOLAR300N and SOLAR I-V are used for MPP300 settings, to start/stop recording electrical and environmental parameters and to enable the download of the recorded values.

The distance between the photovoltaic modules and the inverter is often considerable, and this forces the operator to carry out measurements in different places at the same time. Therefore, it would be necessary to lay long connection cables between the environmental probes and the instrument. These cables could hamper the operator’s movements, be a hindrance, etc. This kind of connection is therefore not acceptable. In case of photovoltaic installations on buildings, the so-called photovoltaic roofs, in addition to the problem of the distance between modules and inverter, the presence of floors, of reinforced concrete or metal structures, etc. must be taken into consideration. These structures would make a possible (wireless) radio connection between the environmental probes and the instrument impossible, because of signal attenuation. In order to avoid the above-mentioned problems and to carry out measurements with the necessary contemporaneity, MPP300 is synchronized with the remote unit SOLAR-02 (provided as standard accessory of master instrument SOLAR300N or SOLAR I-V). The remote unit SOLAR-02 is positioned next to the photovoltaic modules and it is connected to the probes for measuring environmental parameters (irradiation and temperature). MPP300 is connected upstream and downstream of the inverter in order to acquire the electric parameters (continuous power and alternating power).

The synchronization between the two units guarantees the necessary contemporaneity of measurements, the two separate and independent units make measurements comfortable and safe.

The master instrument SOLAR300N or SOLAR I-V is only used in the initial and final phase of recording, and it does not play any active role while recording electrical and environmental parameters. Therefore, while MPP300 and SOLAR-02 respectively record the electrical and environmental parameters of the system being measured, it is possible to use the master instrument SOLAR300N or SOLAR I-V for carrying out other measurements. For example, with SOLAR I-V it is possible to measure the I-V characteristics of strings and modules.

FUNCTIONS

- DC/AC TRMS voltage meas. (single-phase and three-phase)
- DC/AC TRMS current meas. (single-phase and three-phase)
- DC/AC power measurement (single-phase and three-phase)
- Power factor measurement (single-phase and three-phase)
- Simultaneous measurements up to 3 strings (max 3 MPPT)
- Connection with master unit SOLAR300N and SOLAR I-V
- Power supply with rechargeable Li-ION battery
- LED operating indications
- USB port for connection to unit SOLAR300N
- RF connection for connection to SOLAR-02 and SOLAR I-V
- Internal memory for saving recordings

GENERAL CHARACTERISTICS

| | |
|----------------------------|---|
| Inputs: | 3 DC voltage channels (CH1, CH2, CH3), 3 DC current inputs (CH1, CH2, CH3), 4 AC voltage inputs (L1, L2, L3, N), 3 AC current inputs (L1, L2, L3) |
| Front panel: | 4 two-colour LEDs (green, red) |
| Power supply: | Rechargeable Li-ION battery. Duration > 3 hours |
| Internal memory: | 2 MBytes |
| External interface: | USB + RF |
| Safety: | IEC/EN61010-1 |
| Insulation: | double insulation |
| Pollution level: | 2 |
| Mechanical protection: | IP40 (open), IP65 (closed) |
| Measurement category: | CAT IV 300 V AC (to earth), 600 V AC (between inputs) CAT III 1000 V DC (to earth), 1000 V DC (between inputs) |
| Size: | 300 x 265 x 140 mm |
| Weight (battery included): | 2.3 kg |

| ACCESSORIES PROVIDED | Code |
|---|-----------|
| Series accessories | |
| Set of 2 cables, 2m, for DC voltage measurement, 3pcs | KITMPPDCW |
| Set of 2 alligator clips for DC voltage measurement, 3pcs | KITMPPDCC |
| Set of 4 cables, 2m, for AC voltage measurement | KITMPPACW |
| Set of 4 alligator clips for AC voltage measurement | KITMPPACC |
| Rechargeable Li-ION battery | |
| AC/DC battery charger power supply | A0055 |
| USB cable | C2007 |
| Carrying bag for accessories | BORSA2051 |
| User manual on CD-ROM | |
| Quick guide for use | |
| ISO9000 calibration certificate | |
| Opzional accessories | |
| Transducer for AC 0÷200A, diameter 40mm | HT4005K |
| Unbatteried transducer for AC/DC currents 0÷10A, 0÷100A, max. diameter 32mm | HT4004P |
| Rigid clamp AC 1-100-1000A/1V, diameter 54mm | HT96U |
| Rigid clamp AC 10-100-1000A/1V, diameter 54mm | HT97U |
| Rigid clamp DC 1000A/1V, diameter 50mm | HT98U |
| Rigid clamp AC 200-2000A/1V, diameter 70mm | HP30C2 |
| Rigid clamp AC3000A/1V, diameter 70mm | HP30C3 |
| Flexible clamp AC 3000A, diameter 174mm | HTFLEX33D |
| Flexible clamp AC 3000A, diameter 274mm | HTFLEX35 |
| Connector with magnetic tip | 606-IECN |



Useful carrying case for transport



Multi-string PV plant tested by means of MPP 300

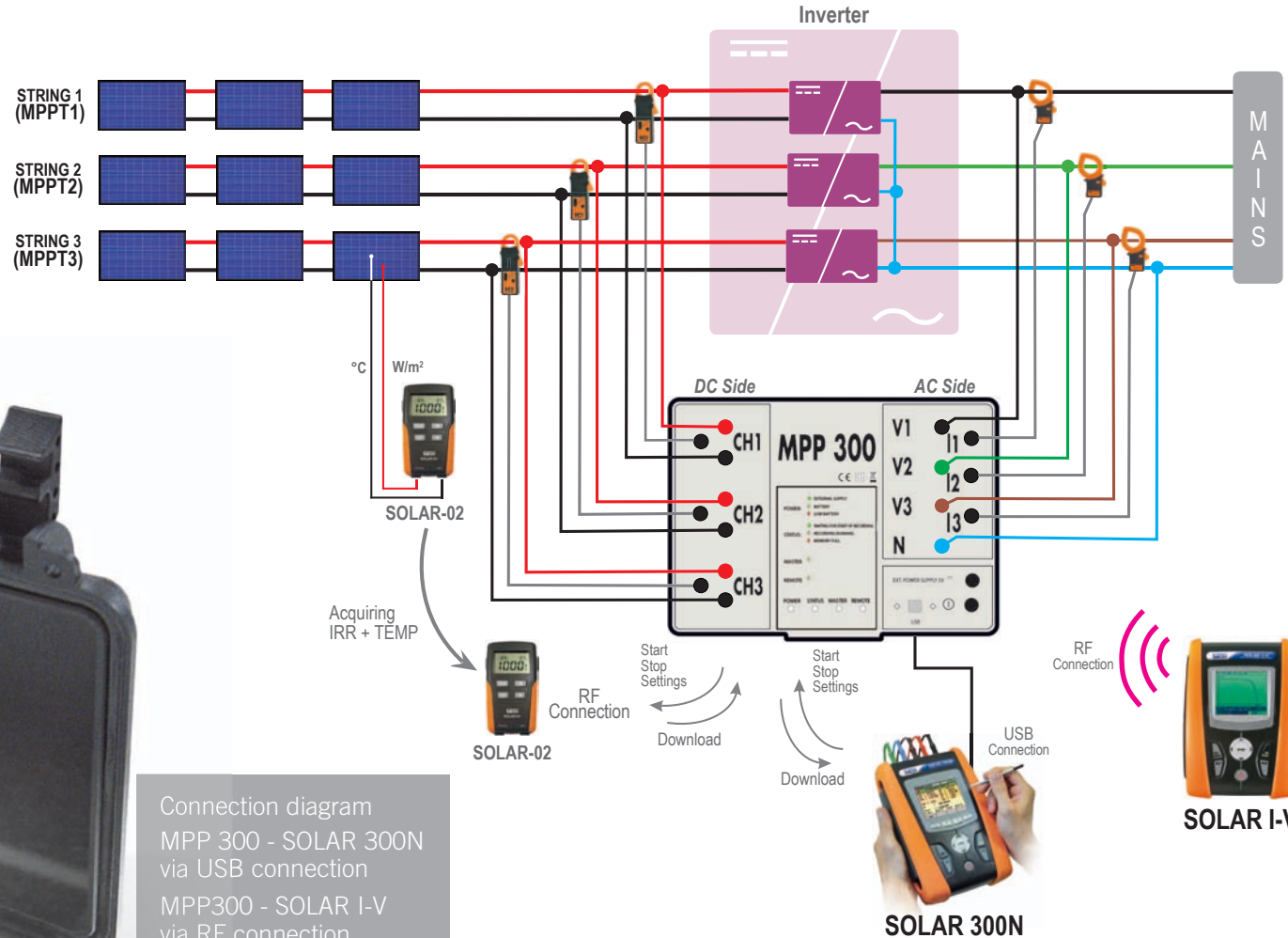

Connection diagram
 MPP 300 - SOLAR 300N
 via USB connection
 MPP300 - SOLAR I-V
 via RF connection



NEW
MPP 300
 HVMP300

SOLAR 200

MULTIFUNCTION INSTRUMENT FOR SAFETY VERIFICATION OF SINGLE-PHASE AND THREE-PHASE PHOTOVOLTAIC SYSTEMS

SOLAR200 is an innovative instrument designed for carrying out electrical safety verifications on photovoltaic systems in compliance with the relevant safety requirements. The instrument is very easy to use and has a wide range of functions which can be selected by means of the simple multi-language menu. Measurements can be started both by pressing the button located on the instrument body and by pressing the button located on the remote probe (optional accessory PR400) which makes carrying out more measurements in sequence very simple. The help on line, which can be selected by the user and is active for any function, is a valid support for the connection of the instrument to the system to be tested. SOLAR200 is provided with an internal memory and an optical/USB interface for PC connection and for transferring measured data, which can be analyzed with the dedicated software.

FUNCTIONS

- Continuity of protective conductors with 200mA
- Insulation with test voltages of 50, 100, 250, 500, 1000VDC
- Tripping time of RCDs type A, AC, general and selective, with nominal current up to 500mA
- Tripping current of RCDs type A, AC, general and selective, with nominal current up to 500mA
- Impedance of Loop/Line P-N, P-P, P-PE, also with high resolution (0,1mΩ with optional accessory IMP57), and Ipsc calculation.
- Total earth resistance with no RCD tripping
- Contact voltage
- Phase sequence
- Activation of measurements with optional remote probe PR400
- Help on line on the display
- Saving of results
- Optical/USB interface for PC connection

GENERAL CHARACTERISTICS

| | |
|-------------------------|--|
| Display: | LCD custom, backlit |
| Power supply: | 6x1.5V alkaline bat. type AA IEC LR06 |
| Internal memory: | 500 locations |
| PC interface: | optoisolated optical connector |
| Safety: | IEC/EN61010-1 |
| Insulation: | double insulation |
| Pollution degree: | 2 |
| Measurement category: | CAT III 240V (to earth), CAT III 415V (between inputs) |
| Reference standards: | IEC/EN61557-1 |
| Dimensions: | 235x165x75mm |
| Weight (bat. included): | approx. 1.25kg |

ACCESSORIES SUPPLIED

| Series accessories | Code |
|--|--------------|
| Cable with three-pin shuko plug | C2033X |
| Kit of 3 cables + 3 alligator clips + 1 probe | UNIVERSALKIT |
| Transport bag | BORSA75 |
| User manual | |
| Calibration certificate ISO9000 | |
| Optional accessories | |
| Windows software for PC + optical/USB cable | TOPVIEW2006 |
| Remote probe for test activation | PR400 |
| Accessory for measuring loop impedance with high resolution | IMP57 |
| Kit of belts for slinging the instrument over one's shoulder | SP-0400 |



SOLAR200
HV000200



IMP57
Accessory for measuring loop impedance with high resolution



PR400
Remote probe

THT41

INFRARED THERMAL CAMERA FOR PROFESSIONAL USE

THT41 is a hand-held infrared camera developed to quickly become the technician's best friend. In a rugged and ergonomic design, THT41 is robust and shock-resistant for any working environment. The instrument has a colour LCD display, saves the images on SD-card in standard JPG format. It also allows transferring the data onto the PC via USB interface. THT41 is specifically designed for products predictive maintenance, electrical inspections, non-destructive testing, process control applications, quarantine inspection, security monitoring solutions, firefighting finding and rescue, building energy testing and diagnostics, veterinarian helper, etc.

| ACCESSORIES | Code |
|---------------------------------|-----------|
| Standard accessories | |
| 11mm lens and protection cover | |
| 2GB SD card and card reader | |
| 12 AA rechargeable batteries | |
| AC adapter | |
| USB extension cable | |
| USB driver | |
| Wrist strap | |
| Windows ThermoViewPRO software | |
| User manual | |
| ISO9000 calibration certificate | |
| Safety case | |
| Optional accessories | |
| Sun shield | SSHIELD49 |
| Universal tripod adapter | TRIPO49 |

GENERAL CHARACTERISTICS

| | |
|------------------------------|--|
| Measuring range: | -20°C ÷ 250°C |
| Thermal sensitivity: | 0.1°C @ 30°C |
| Field of view (FOV): | 21°x16° (11mm lens) |
| Precision: | ±2%reading or ±2°C |
| IR sensor resolution: | 160x120pxl |
| TFT colour display: | LCD, 3.6" |
| Focusing: | manual |
| Image frequency: | 50Hz |
| Emissivity correction: | 0.01 1.00 |
| Measuring cursors: | hot / cold point |
| Measuring functions: | correction according to distance, reflected temperature, relative humidity |
| Storage of images: | SD Card 2GBytes |
| Image format: | standard JPG |
| Saved images: | > 1000 |
| Power supply: | 6x1.2V NiMH batteries type AA |
| Duration: | > 2 hours |
| Mechanical protection: | IP54 |
| Size (LxWxH): | 240 x 111 x 124mm |
| Weight (batteries included): | 0.73kg |



Complete set for transport of accessories

Thermal image of defective PV modules

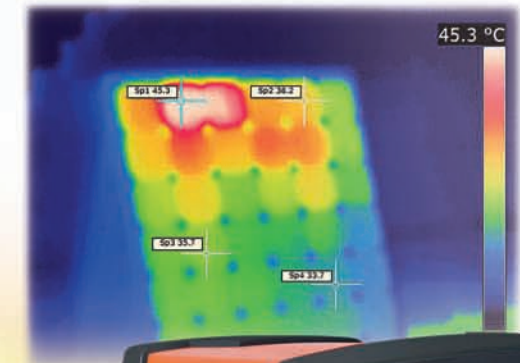

NEW

THT41
HN000041

Q1

UNIVERSAL CRIMP TOOL

Special tool for cabling photovoltaic systems. It has the following characteristics:

- in hardened and tempered chrome-vanadium steel
- handles in non-slip material, two components
- interchangeable dies and locators allow working with different types of connectors with a single tool

The high-precision crimp tool Q1 has been designed to guarantee professional connections with a single manual tool. The tightening force is multiplied thanks to an internal system of levers which allows a 30% reduction of the force normally necessary. Q1 is provided with a practical case in anti-shock resin without dies and without locators, with:



- crimp tool Q1
- L wrench for die assembly
- adjustable wrench

Customization according to requirements with the available dies and locators (special dies available on demand)

Interchangeable dies and locators

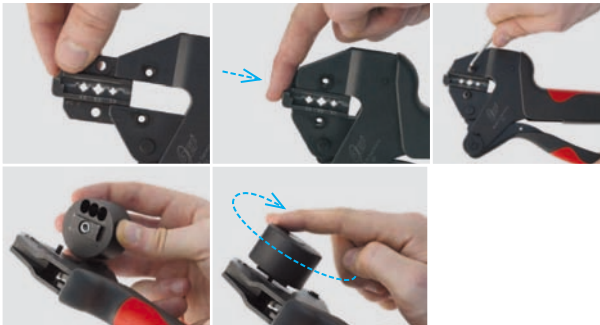
Thanks to the locator, the terminal is always crimped in the correct position, thus simplifying the operation, without the need to use "three hands" for crimping. A wide range of dies is available, in order to satisfy the requirements of most modern connectors.



| DIES |  |  |  |  |  |
|-----------------------------|--|--|--|--|--|
| Type of connector | MC3 | MC4 | Tyco | Huber & Shuner | Huber & Shuner |
| Metel code | HU000664 | HU000662 | HU000660 | HU000692 | HU000671 |
| Diameter (mm ²) | 2,5/4,0/6,0 | 2,5/4,0/6,0 | 1,5/2,5/4,0/6,0 | 2,5/4,0 | 4,0/6,0 |

| LOCATORS |  |  |  |
|------------|---|---|---|
| Type | MC3 | MC4 | Tyco |
| Metel code | HU000663 | HU000661 | HU000559 |



SPECIAL TOOL FOR MC3 ASSEMBLY (inserting the rubber connector onto the crimped cable)

Q2 is a practical clamp for mounting connector MC3 once the terminal has been crimped to the cable. The 3 thimbles provided allow assembly on cables with different diameters (from 2.5 to 10 mm²). Thanks to its small size (325 mm) and its weight (460 g), this tool can be used directly on site and even on a roof. Lightweight and portable, it is made of anti-shock plastic.

Mounting examples of MC3 with Q2



Prepare crimped connector MC3 and the insulating connector (male or female)



Choose the thimble according to cable diameter

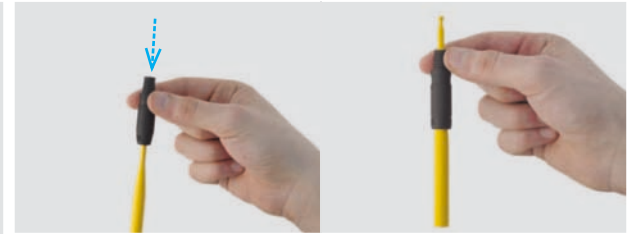

With the right hand, completely insert the MC3 connector into the thimble



Insert the thimble with the connector into the appropriate housing for the cable

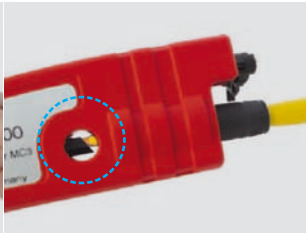

Press the clamp until the thimble is completely inserted in the connector and insert the crimped cable, and fasten it with the relevant cable holder.



Continue pressing the tool until no resistance is felt. Then remove the cable by extracting the relevant cable holder. By using this innovative tool, it is possible to cable systems directly on site, thus saving installation times and costs.



Built-in thimbles

Safety closure

Inspection window

Cable housing and holder

NEW
TOP QUALITY
MADE IN GERMANY
MOUNTING OF MC3
**INNOVATIVE
AND SIMPLY**



Q2
HU000675



Photovoltaic installations are becoming more and more popular

While the costs of components are decreasing and their performance is significantly booming up, the photovoltaic installations are very common either on buildings' roofs or installed on the ground.

The problems involved in the installation of photovoltaic systems, however, are to be solved in terms of safety, testing and maintenance requiring specific solutions.

Why to use a reference cell

Photovoltaic modules partially convert solar radiation into electric power. The efficiency of photovoltaic modules is strongly affected by several factors such as:

- operating temperature of modules;
- manufacturing technology of modules;
- angles at which solar radiation hits the modules' surface;
- spectral composition of solar radiation; etc.

It is obvious that, to properly evaluate the performance

of the photovoltaic modules under test, it is necessary to measure the solar radiation which they are subject to by means of a transducer with features similar to the modules' ones. Using a sensor with a different manufacturing technology could lead to inconsistent measurements of solar radiation, and consequently to incorrect measurements of the modules under test. For this reason HT photovoltaic testers are provided with the reference cell HT304 as standard accessory.

HT304 is featured as follows:

- it is provided with a built-in temperature sensor allowing

compensation of the measured values;

- it is provided with two sensors made of monocrystalline and polycrystalline silicon respectively to better suit the manufacturing technology of the modules to be tested;
- it better reflects the close correlation of the modules under test with the solar radiation incidence angle as well as with its spectrum composition;
- it grants a quick response the same as the photovoltaic modules.

This last feature is crucial in case of measurements taken under conditions of variable cloudiness.

SAFETY WITH SOLAR 200

The photovoltaic installation is an electrical system under all respects and its safety must be certified in compliance with the regulations in force.

As the photovoltaic modules are installed outdoors and directly irradiated by the sun, they are subject to extreme environmental conditions such as hot weather in summer, frost in winter, rain and hail etc.

All this makes safety testing even more necessary.

Safety is not to be neglected in the assembly and maintenance of a photovoltaic installation.

The regulations in force state that quality marks and certification on components are not enough and that an instrumental measurement is required.

TESTING WITH SOLAR 300N AND SOLAR I-V

To apply for special tariffs the electricity user needs to provide a test certificate along with sundry documents. This document certifies that the installation ensures a minimum efficiency level. It is therefore necessary to employ measuring instruments bringing about significant practical problems.

In a typical building installation modules are usually placed on the roof and the inverter is often in the basement.

Such a condition is critical because, to test the equipment both electrical and environmental parameters are to be measured simultaneously even though very far from each other. Only the use of suitable equipment can grant correct measurements carried out in a suitable, fast and convenient way.

MAINTENANCE I-V400 AND SOLAR I-V

The outdoor installation, with consequent exposure to extreme environmental conditions, can lead to a rapid deterioration of the modules as well as a sharp decrease in the performance of the whole photovoltaic installation.

The energy produced and the consequent economic benefit can be reduced considerably. It should be advisable therefore to periodically check the installation comparing the performance of the modules as specified by their manufacturer. By measuring the module I-V feature and comparing it with the rating you can assess whether they are granting adequate performances, whether any decrease falls within the natural performance decay, or whether one or more modules are faulty.

In this case you can pinpoint the damaged modules and promptly replace them.

