



DESPRE NOI:

Domeniul de activitate al **SC GAAN COM 94 SRL** IL REPREZINTA PRODUCTIA DE MASINI ,UTILAJE SI MOBILIER TEHNOLOGIC PENTRU INDUSTRIA DE CONFECTII, PRECUM SI COMERCIALIZAREA DE ACCESORII,PIESE DE SCHIMB SI CONSUMABILE.

PRODUSE:

MASINI SI UTILAJE

1) MASINA DE TERMOCOLAT RELIANT R 600



Masina de termocolat RELIANT R600 este destinata exclusiv industriei usoare pentru aplicarea intariturilor pe materialele textile fiind in conformitate cu normele in vigoare.

Gabaritul redus si fiabilitatea elementelor constructive o face utila in spatii de productie mici ducand la cresterea productivitatii.

Masina de termolipit este formata din:

1. Cadru metalic
2. Traversa superioara
3. Traversa inferioara
4. Tablou electric
5. Panou frontal de comanda
6. Mese auxiliare
7. Comutator retea

CARACTERISTICI TEHNICE:

- 1) consum orar: 2.1KW/h
- 2) alimentare: 380 V
- 3) latimea utila a benzii: 600 mm.
- 4) viteza reglabila
- 5) temperatura reglabila 0 – 300 C
- 6) presiune reglabila in functie de materialul termocolat
- 7) sistem automat de oprire

GARANTII:

Pentru utilaj: 12 luni

Pentru benzile de teflon: 6 luni.

EXECUTAM BANDA RELIANT ORICE DIMENSIUNE CU SAU FARA CAPSE !!!!!!!

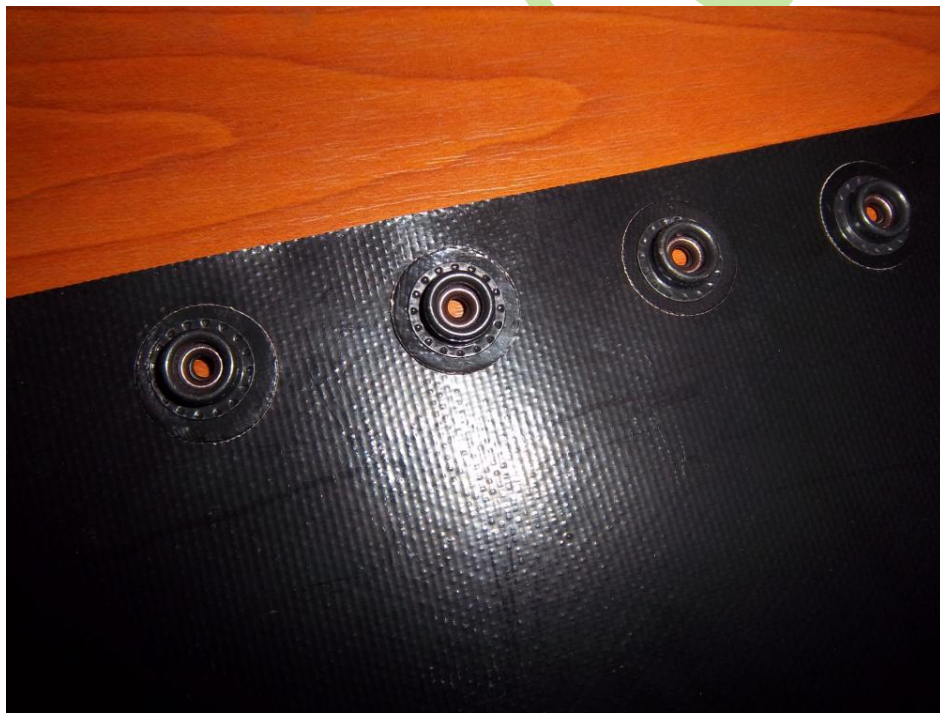

2)MASINA DE CROIT CU BANDA CONTINUA BANDSEG



DESCRIERE:

Mașina de croit cu banda este destinată fabricilor de confecții pentru tăierea materialelor textile fiind compusă din:

- sasiu
- blat
- motor
- dispozitiv de întindere a benzii
- dispozitiv de ascuțire a benzii
- dispozitiv de reglare a șpanului

- roți antrenoare
- apărători și dispozitive de protecție
- întrerupător
- cablu cu fișă de alimentare la rețea
- roți mobile pentru deplasare
- picioare reglabile pentru amplasare
- roți pivotante pentru deplasare

CARACTERISTICI TEHNICE

- | | |
|--|----------------|
| a) Alimentare: | 380 V/220 V |
| b) Putere: | 1.5 KV |
| c) Viteza motorului: | 1410 rot./min. |
| d) Viteza benzii tăietoare: | 7,7 m/s |
| e) Lungimea benzii tăietoare: | 3360 mm. |
| f) Dimensiunile curelei de transmisie: | 1218x10x6mm. |
| g) Greutate: | 90 kg. |
| h) Dimensiune blat: | la cerere |

3. MASINA TERMOLIPIT SACI



900 X 1400 X 900

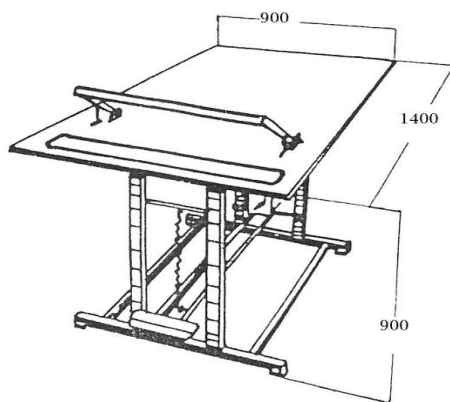

MASINA TERMOLIPESTE SACII CU CARE SE AMBALEAZA PRODUSELE FINITE.DIMENSIUNI 900*1400*900.

4.1 SCAUN ERGONOMIC CU INALTIME REGLABILA





- blat si spatar din placaj si PFL cires sau fag
- inaltime reglabila
- inaltimea maxima : 700 mm
- inaltimea minima : 470 mm.
- SE POT EXECUTA SI INALTIMI MAI MARI PENTRU MASINILE SPECIALE.

4.2 SCAUN FIX





4.3 SCAUN INALT CU INALTIME REGLABILA



4.4 SCAUN INALT FIX



4.5 TAMBUR CU INALTIME REGLABILA



4.6 SCAUN INALTIME REGLABILA CU ROLE



5.MOBILIER TEHNOLOGIC

1) MASA DE CROIT







DIMENSIUNILE SE LUCREAZA IN FUNCTIE DE SPATIUL DE LUCRU LA CEREREA CLIENTULUI.

2.DISPOZITIV DE FIXARE A FOILOR DE SPAN LA CAPETE CU ACTIONARE LA PICIOR (DISPOZITIV "CAP SPAN")



DISPOZITIV DE FIXARE A FOILOR
DE SPAN LA CAPETE, CU
ACTIONARE LA
PICIOR, DISPOZITIV "CAP SPAN"
1700 X 100 X 100

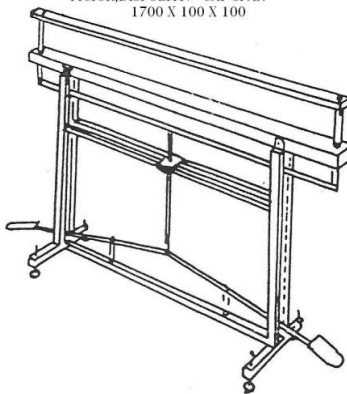

3. MASA DE LUCRU CU SERTARE



6.CARUCIOARE TRANSPORT

1.1CARUCIOR TRASPORT BALOTI.

DIMENSIUNI 820 X 1600 X 920 (SE POATE EXECUTA ORICE DIMENSIUNE LA CERERE)



1.2 CARUCIOR TRANSPORT PRODUES FINITE

DIMENSIUNI 800 X 1350 900 (SE POATE EXECUTA ORICE DIMENSIUNE LA



CERERE)

1.3 CARUCIOR TRANSPORT "TIP PLATFORMA"

DIMENSIUNI 600 X 1200 X 935 (SE POATE EXECUTA ORICE DIMENSIUNE LA



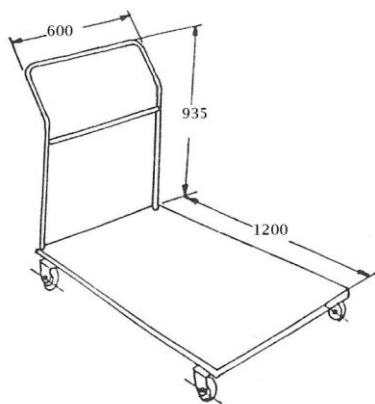

CERERE)

1.4 CARUCIOR TRANSPORT ,DIMENSIUNI 1200 X 600 X 700 (la comnda se pot executa la orice dimensiuni)



**1.5 CARUCIOR TRANSPORT 1200X800X200 (SE POATE EXECUTA
ORICE DIMENSIUNE)**





1.6 CARUCIOR METALIC INCHIS CU 2 USI BATANTE 850X450X900



1.7 CARUCIOR 1.7



1.8 CARUCIOR DEPOZIT CU SCARA



7. STENDER

7.1 STENDER MOBIL 600X1800X1500 (SE POATE EXECUTA ORICE DIMENSIUNE LA CERERE).



7.2 STENDER CU 2 BARE

STENDER
CU 2 BARE

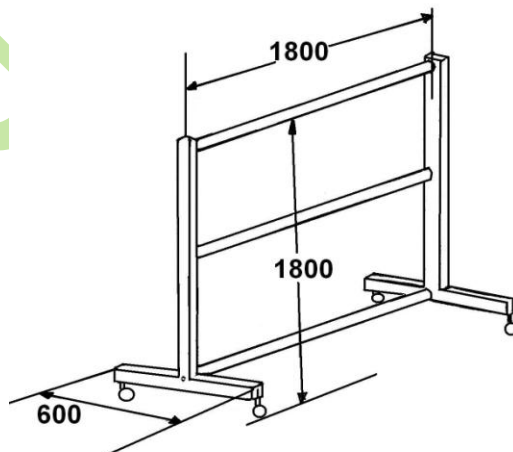

7.3 STENDER CU 3 BARE SI 2 NIVELE

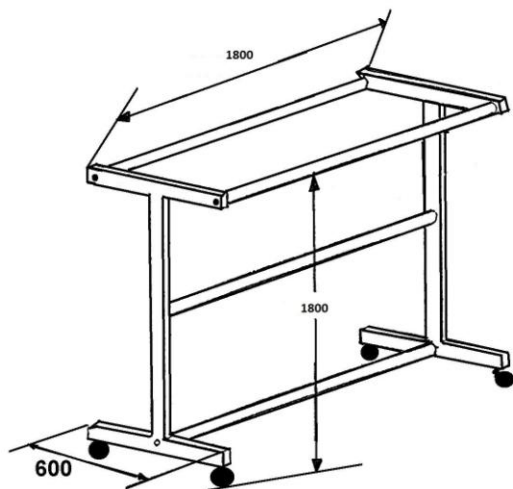

7.4 STENDER BAZA "Z"

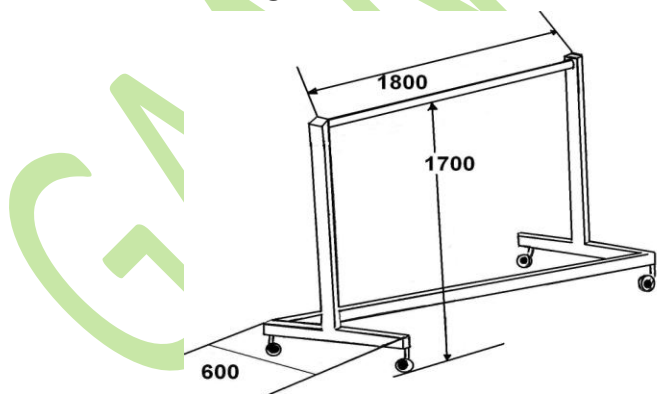

STENDER
BAZA "Z"



8. PLATFORMA MOBILA

DIMENSIUNI ---- SE EXECUTA LA COMANDA

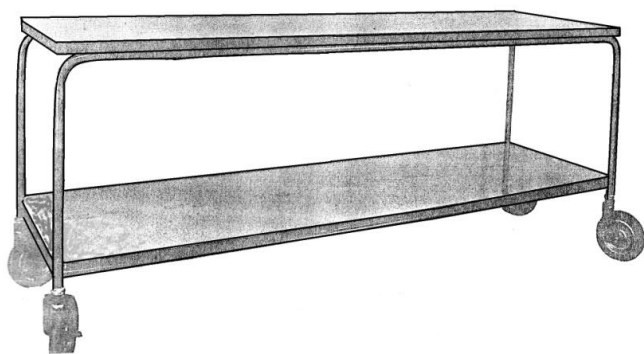

9. RAFTURI SI MESE MOBILE *** DIMENSIUNILE SE EXECUTA LA COMANDA.

RAFT CU POLITE MOBIL

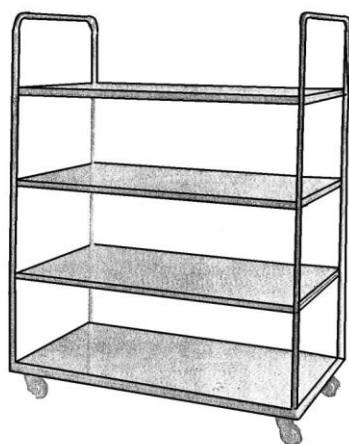

MASA MOBILA



10. CARUCIOARE INTEROPERATIONALE

2.1 CARUCIOR INTEROPERATIONAL 700x600x380 SE POT ATASA

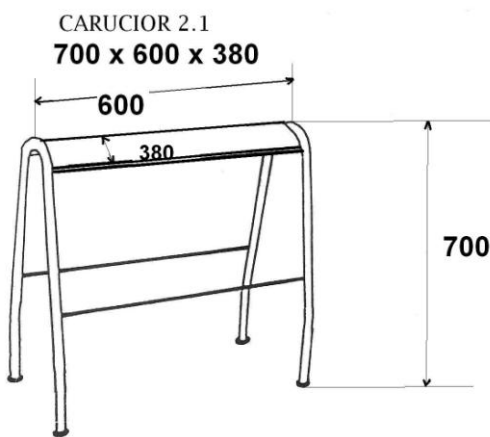

ROTI

2.2 CARUCIOR INTEROPERATIONAL 700X650X380 SE POT ATASA

CARUCIOR 2.2
700X650X380

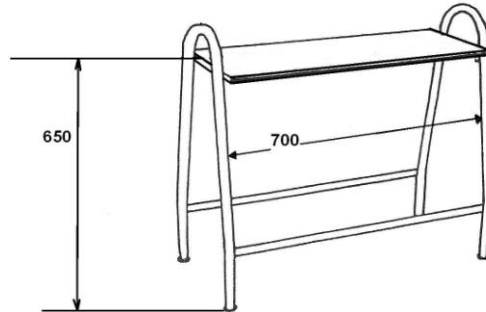

ROTI

2.3 CARUCIOR INTEROPERATIONAL 680X770X350

CARUCIOR 2.3
680 X 700 X 350

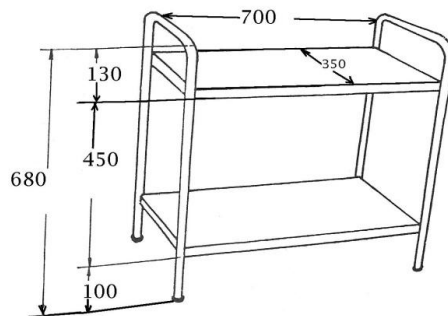

2.4 CARUCIOR INTEROPERATIONAL 700x650x400

CARUCIOR 2.4
700 X 650 X 400

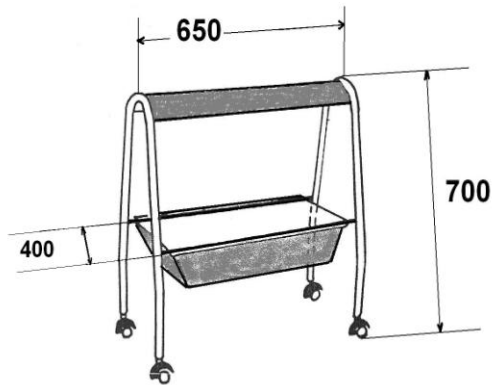

DIMENSIUNI COS:600X400X130

2.5 CARUCIOR INTEROPERATIONAL 700 X 350 X 720 mm.



CARUCIOR 2.5
350 X 720 X 700

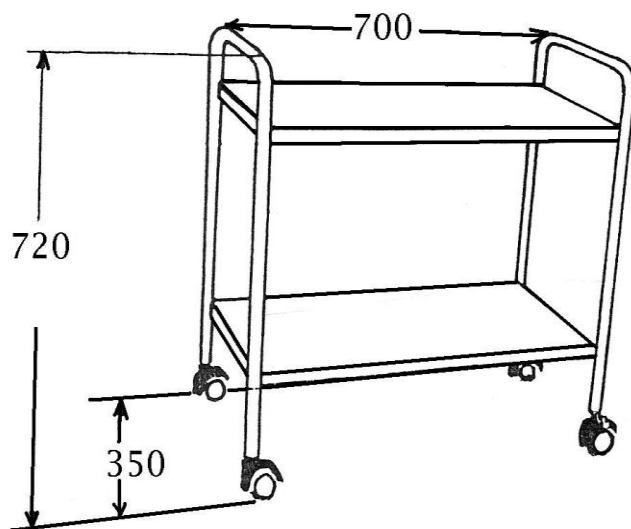

2.6 CARUCIOR INTEROPERATIONAL

CARUCIOR 2.6
400 X 650 X 320

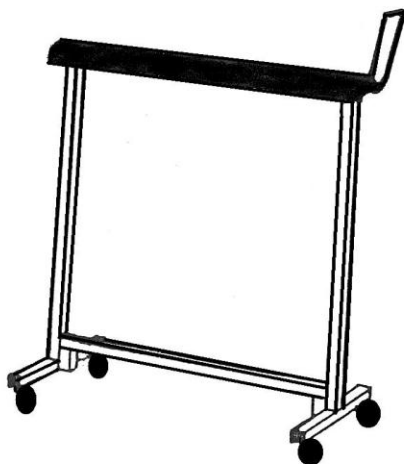

2.7 CARUCIOR INTEROPERATIONAL 2.7



2.8 CARUCIOR INTEROPERATIONAL 2.8



2.9 CARUCIOR INTEROPERATIONAL 2.9



GAAN.COM

2.10 CARUCIOR INTEROPERATIONAL 2.10



2.11 CARUCIOR INTEROPERATIONAL 2.11 (SE POT ATASA ROTI)



VARIANTA CU ROTI



2.12 CARUCIOR INTEROPERATIONAL 2.12



2.13 CARUCIOR INTEROPERATIONAL 2.13



2.14

2.14 CARUCIOR INTEROPERATIONAL 2.14



2.15 CARUCIOR INTEROPERATIONAL 2.15 , 600 X 420 X 800





2.16 CARUCIOR 2.16 CU 2 COSURI 650X410X650

**CARUCIOR 2.15
CU 2 COSURI
650X410X650**

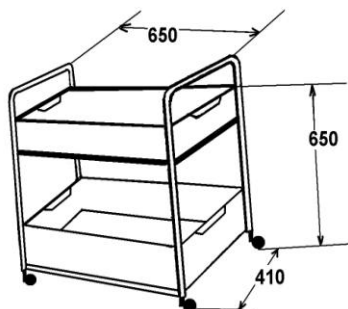

2.17 CARUCIOR INTEROPERATIONAL L=680,I=535,H=680





2.18 CARUCIOR



2.19 CARUCIOR CU COS SI PLATFORMA RABATABILA



2.20 CARUCIOR PLATFORMA RABATABILA SI BAZA "Z" OCUPA SPATIU MIC



DE DEPOZITARE

11.MESE DE LUCRU SI INTEROPERATIONALE.DIMENSIUNILE SE EXECUATA LA CERERE.

MODUL MASA DE LUCRU, INTEROPERATIONALA

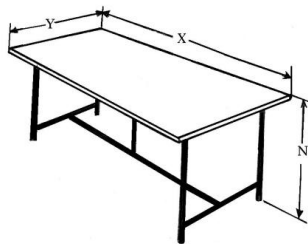

12.COSURI INTERFAZICE



13.STELAJE REPERE SI ACCESORII,RAFTURI MODULARE PENTRU DEPOZITAT .

DIMENSIUNILE SE EXECUTA LA COMANDA.







14. TRONSON ILLUMINAT



15.FOARFECI CROITORIE



FOARFECA 110/4"



FOARFECA 111/4"



FOARFECA 232/ 5",6",7"



FOARFECA 840/4". VARF CURBAT



FOARFECA 310/3,5" .6" ,7" ,8"



FOARFECA 421/6" ,7" ,8" ,9"



FOARFECA 625/ 7" ,8" ,9" ,10" ,11" ,12"

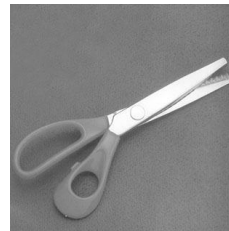

FOARFECA ZIMTATA 525/7

FORFECUTA TAIAT ATA CU SAU FARA MANER PLASTIC.

16.BANDA RELIANT CU SAU FARA CAPSE,CU SAU FARA INTARITURA PE LATERALE.





17. Mobilier sala de mese (Mese si scaune)





18. SUPORT SAC GUNOI





SC GAAN COM '94 SRL

Producator de masini, utilaje si mobilier pentru fabricile de confectii; accesorii.



Str. SF. ANDREI NR. 5, POPESTI LEORDENI, JUD ILFOV

**J40/13782/94; C.F.RO 6243769; Mobil: 0744.567.299 ; 0744.435.064; e-mail:
gaan94@gmail.com; gaan94@yahoo.com; <http://www.facebook.com/pages/GAAN-COM-94/151630901590603>**

Producator de masini, utilaje si mobilier pentru fabricile de confectii; accesorii.